

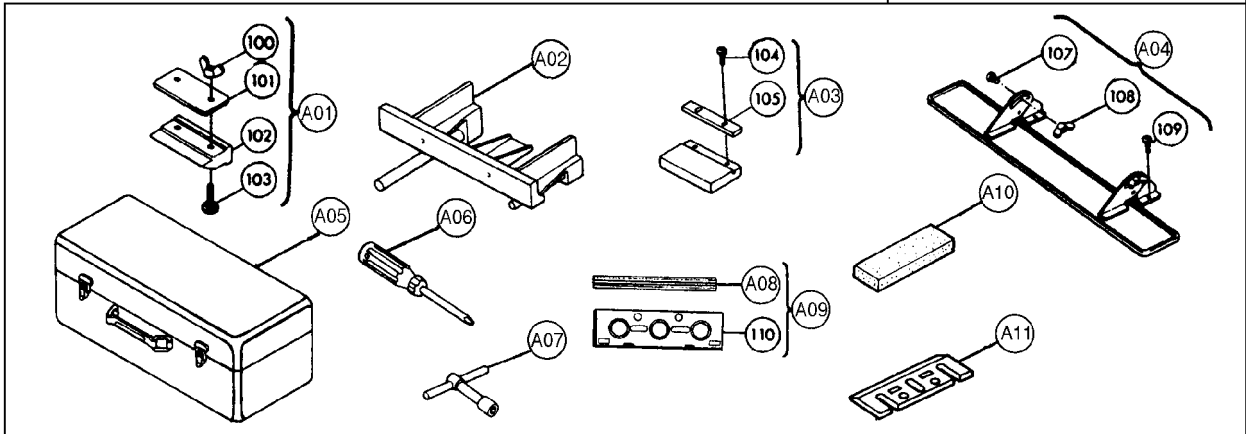

3-1/4" POWER PLANER

Model 1100(MJ)

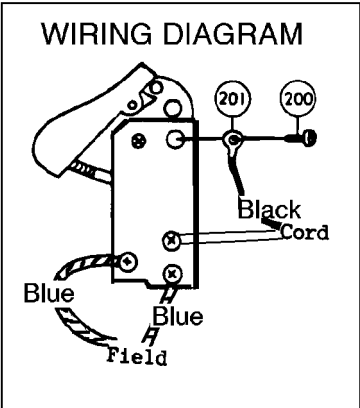
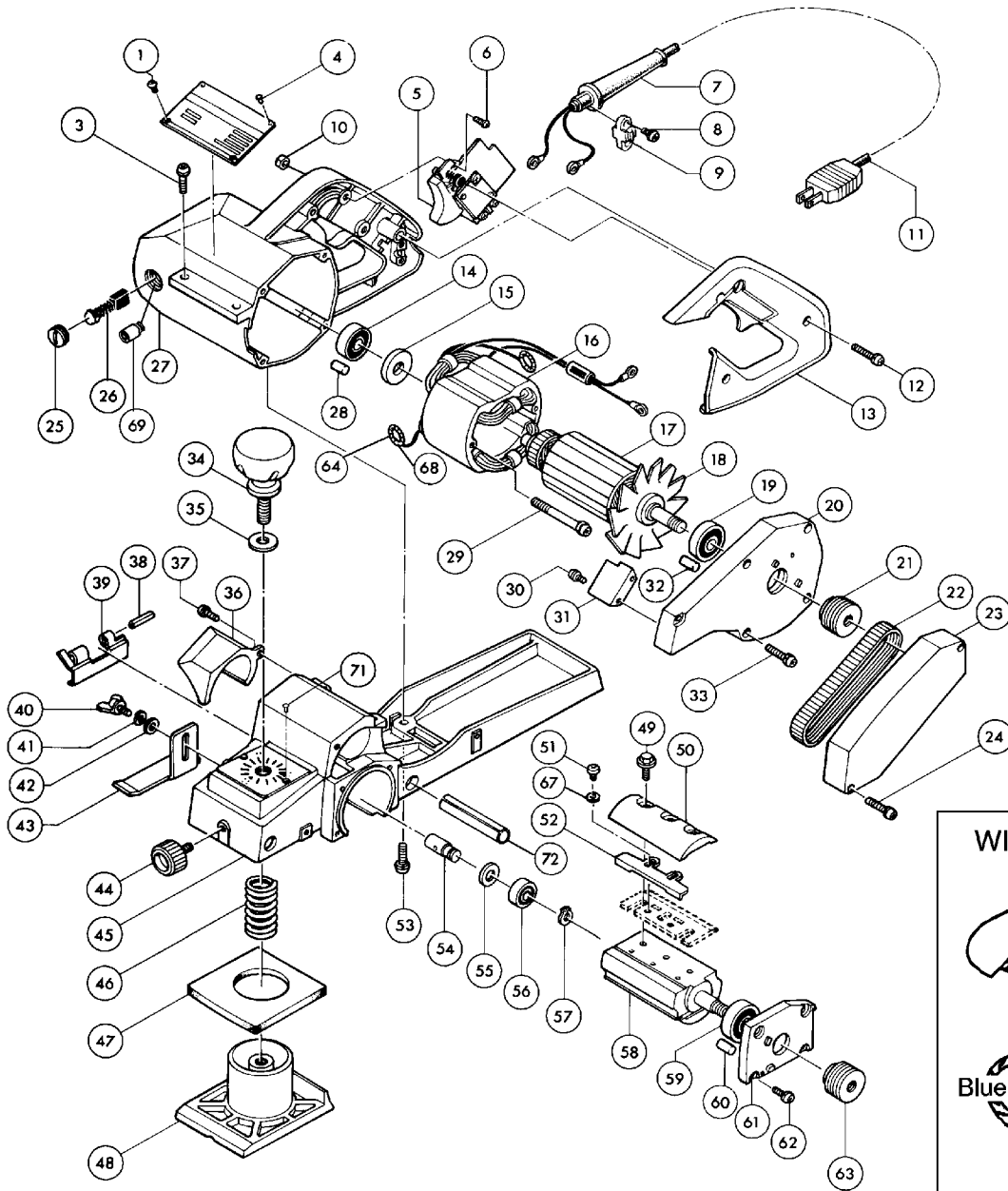

Item No.	Part No.	No. Used	Description	Item No.	Part No.	No. Used	Description
1	911001-2	2	P.H. Screw M3x6 (With Washer)	51	251246-3	4	(+) P.H. Screw M4x5
2	*	2	P.H. Screw M4x14	52	342430-2	2	Adjust Plate
3	911228-4	2	P.H. Screw M5x18 (With Washer)	53	911226-8	2	P.H. Screw M5x18 (With Washer)
4	931106-2	2	Rivet 0-5	54	323001-4	1	Drum Rear Shaft
5	*	1	Switch	55	253139-0	1	Flat Washer 8
6	*	*	P.H. Screw M4x6 (With Washer)	56	211032-4	1	Ball Bearing 608ZZ (Old 210011-9)
7	682502-4	1	Cord Guard 8-85	57	961004-6	1	Retaining Ring S-8
8	911133-5	2	P.H. Screw M4x18 (With Washer) (Old 911131-9)	58	161048-8	1	Drum
9	*	1	Strain Relief	59	211107-9	1	Ball Bearing 6201ZZ
10	931102-0	3	Hex Nut M4	60	263005-3	1	Rubber Pin 6
11	664013-1	1	Cord With Plug 2P-18-2.5	61	312003-5	1	Drum Hsg (Includes Item 60)
12	911153-9	3	P.H. Screw M4x28 (With Washer)	62	911121-2	4	P.H. Screw M4x14 (With Washer)
13	*	1	Handle Cover	63	222001-0	1	V-Pulley 5-29.4
14	211068-3	1	Ball Bearing 6200LB	64	654019-7	2	Garter Spring
15	*	1	Insulation Washer	65	*	2	Flat Washer 5
16	623012-2	1	Field Assy (With Items 64 & 68)	66	*	1	Bearing Cover
17	613002-3	1	Armature Assy * (Includes Items 14, 15, 18 & 19)	67	941052-1	4	Flat Washer 4 (Old)
18	241001-1	1	Fan 80	68	654501-6	2	Solderless Connector P-1.25
19	211066-7	1	Ball Bearing 6200LLB	69	643603-3	2	Brush Holder 6-10 (Type 1)
20	156315-4	1	Bracket (Type 1)(With Item 32)		643609-1	2	Brush Holder (Type 2)
	312246-9	1	Bracket (No Rubber Pin) (Type 2)	70	*	2	Set Screw M5x8
21	222002-8	1	V-Pulley 5-26.5L	71	953106-2	2	Rivet 0-5 (Old)
22	225001-9	1	Poly V-Belt 5-285	72	257533-8	1	Sleeve 10 (Old)
23	411004-1	1	Belt Cover	100	934301-3	2	Wing Nut M6
24	911148-2	2	P.H. Screw M4x25 (With Washer)	101	341003-8	1	Pressure Plate
25	643600-9	2	Brush Holder Cap 6-10	102	411174-6	1	Sharpening Holder
26	191945-4	2	Carbon Brush CB-124(2pcs/Set)	103	251920-3	2	Countersunk Square Neck Bolt M6x30
	191903-0	2	Auto Cut-Off Carbon Brush CB-112 (2pcs/Set)(Optional)	104	911228-4	2	P.H. Screw M5x18 (With Washer)
27	*	1	Motor Hsg (With Items 10, 69 & 70)	105	411086-3	1	Gauge Plate
28	263013-4	1	Rubber Pin 4	107	923211-9	2	Countersunk Square Neck Bolt M5x12
29	911290-9	2	(+) P.H. Screw M5x65 (With Washer & Bond)	108	934201-7	2	Wing Nut M5
30	911101-8	2	P.H. Screw M4x6 (With Washer)	109	911201-4	2	P.H. Screw M5x8 (With Washer)
31	342148-5	1	Baffle Cover	110	*	2	Set Plate(For Mini Planer Blade)
32	263002-9	1	Rubber Pin 4 (Old)		193540-6	2	Set Plate Set (2pcs/Set) (For Mini Planer Blade)
33	911146-6	5	P.H. Screw M4x25 (With Washer)	200	652014-1	4	(+) P.H. Screw M4x8
34	271226-3	1	Knob 50	201	654038-3	4	Insulated Eye Terminal FV1.25-M4
35	941251-5	1	Flat Washer 10	Accessories			
36	312004-3	1	Chip Cover	A01	123004-6	1	Sharpening Holder Assy (Assembled Items 100-103)
37	911136-9	1	P.H. Screw M4x20 (With Washer)	A02	161046-2	1	Guide Rule (Rip Fence)
38	951131-7	1	Spring Pin 4-40	A03	123010-1	1	Blade Gauge Assy (Assembled Items 104 - 105)
39	342002-3	1	Drum Cover	A04	123032-1	1	Bevel Guide Assy (Assembled Items 107 - 109)
40	924206-5	1	Wing Bolt M5x10	A05	823001-9	1	Steel Carrying Case
41	942101-7	1	Spring Washer 5	A06	783002-8	1	(+) Screwdriver 2
42	941101-4	1	Flat Washer 5	A07	782209-3	1	Socket Wrench 9
43	342001-5	1	Depth Guide	A08	793322-2	2	3-1/4" Double Edged Carbide Mini Planer Blade *
44	251804-5	1	Screw M6x12	A09	*	1	Set Plate & Mini Blade (1 set) (Set of Items 110 & A08)
45	156510-6	1	Main Frame (Type 1)(With Item 71)	A10	741802-2	1	Dressing Stone 150-1200(Old 794061-7)
	156371-4	1	Main Frame (Type 2) (With Scale Label - 816774-1)	A11	731001-4	2	3-1/4" High Speed Steel Planer Blade (Old 793004-6)
46	231001-9	1	Compression Spring 17		793007-0	2	3-1/4" Tungsten Carbide Tipped Planer Blade
47	421001-9	1	Rubber Packing				
48	312002-7	1	Front Base				
49	251609-3	6	Hex Flange Head Bolt M6x17				
50	345001-4	2	Drum Plate (Replace both Plates at the same time to ensure Balance of Drum)				

SERVICE CHANGES

1. Change on Switch and Handle Cover.

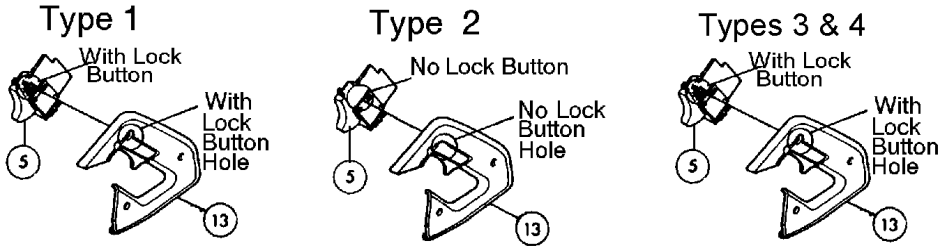

Item No.	Description	Type 1	Type 2	Type 3	Type 4
5	Switch	651007-5 (W/Lock Button) (No Longer Available)	651022-9 (No Lock Button)	651007-5 (W/Lock Button) (No Longer Available)	651016-4
13	Handle Cover	411632-2 (W/Hole)	411611-0 (No Hole)	411632-2 (W/Hole)	

Above parts are completely interchangeable as a set.

2. Change on Armature and Insulation Washer.

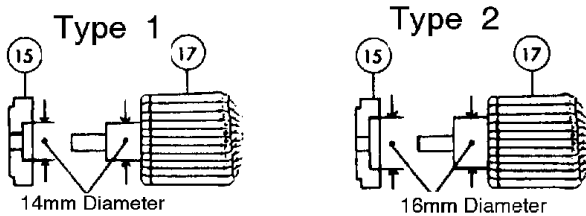

Item No.	Description	Type 1	Type 2
15	Insulation Washer	681607-7 (No Longer Available)	681623-9
17	Armature	613002-3	
		Has 14mm Shaft to accept Washer	Has 16mm Shaft to accept Washer

Type 2 Insulation Washer replaces Type 1 Insulation Washer.

3. Change on Set Plate.

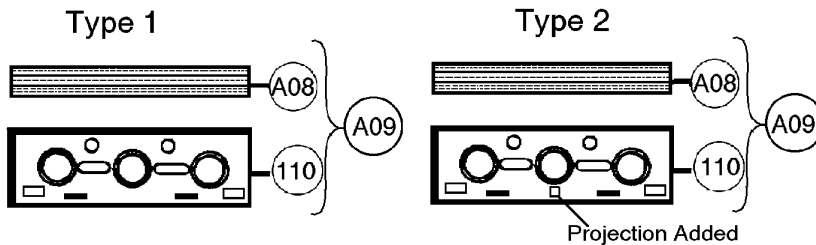

Item No.	Description	Type 1	Type 2
110	Set Plate	341492-7 (No Longer Available)	343433-9
A08	Mini Planer Blade	793222-2	
A09	Set Plate (2pcs) & Mini Planer Blade (1 set)	731209-0 (No Longer Available)	731209-0A

When replacing Set Plate, please change **both** Set Plates with either Type 1 (341492-7) or Type 2 (343433-9) Set Plates otherwise unbalance will occur.

4. Change on Motor Hsg. Com.

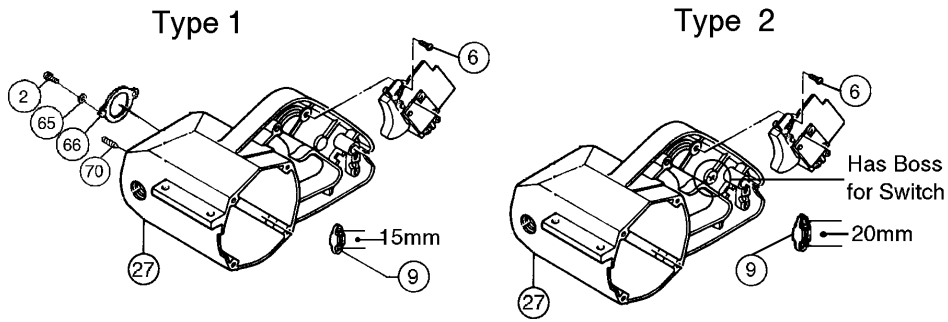

Item No.	Description	Type 1	Type 2
6	P.H. Screw M4x6	911101-8	
		2 Pcs	1 Pc
9	Strain Relief	687002-9	687063-9
27	Motor Hsg. Com.	156308-1 (No Longer Available)	159529-4
	Serial No.	~ 677308	677309 ~
2	P.H. Screw M4x14	911216-1	-----
65	Flat Washer 5	941102-2	-----
66	Bearing Cover	285405-7 (No Longer Available)	-----
70	Set Screw M5x8	913206-0	-----

Above parts are completely interchangeable as a set.